

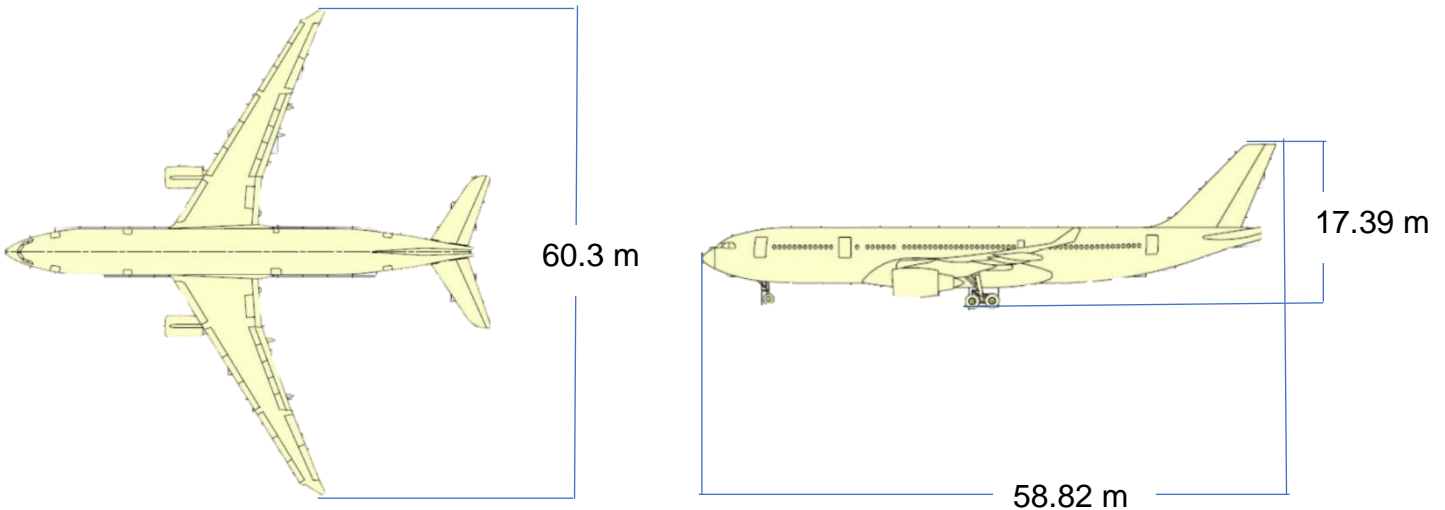

AIRBUS 330-200 P2F

Engines: **Rolls-Royce Trent-700**

Certified Gross Weights		
Description	Pounds	Kilograms
Maximum Payload*	127,868.11	58,000
Maximum Take-Off Weight	513,677.07	233,000
Maximum Landing Weight	401,241.32	182,000
Maximum Ramp Weight	555,344.43	251,900
Maximum Zero Fuel Weight	388,013.58	176,000
Maximum Fuel Capacity	306,640.96	139,090



Deck	Capacity
Main Deck	13,067 ft ³
Lower Deck FWD	2,212 ft ³
Lower Deck AFT	1,896 ft ³
Lower Deck Rear Bulk	695 ft ³
Total	17,870 ft³

mas

Aerotransportes
 Mas de Carga SA de CV
 Hangar 9 y 10, Zona C,
 Zona Federal
 Aeropuerto Internacional (T2)
 CDMX, Venustiano Carranza,
 C.P. 15620
 masair.com



A33-200 Cargo Configuration

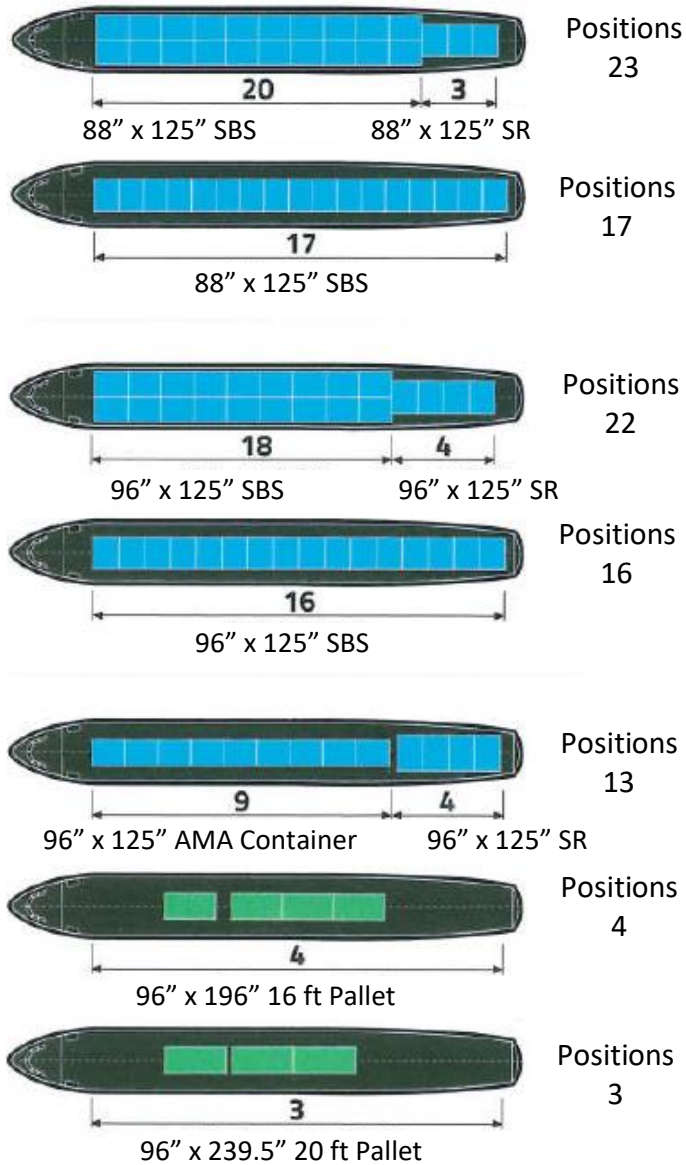

mas

Aerotransportes
Mas de Carga SA de CV
Hangar 9 y 10, Zona C,
Zona Federal
Aeropuerto Internacional (T2)
CDMX, Venustiano Carranza,
C.P. 15620
masair.com



Dimensions Loading Doors – Main Deck

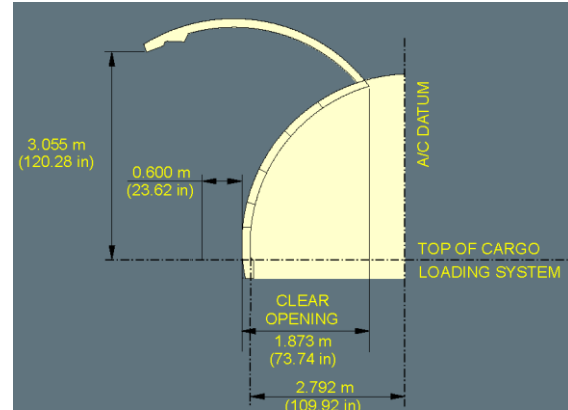
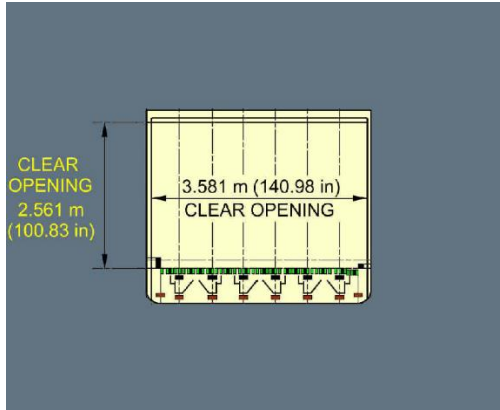

Dimensions Loading Doors – Lower Deck

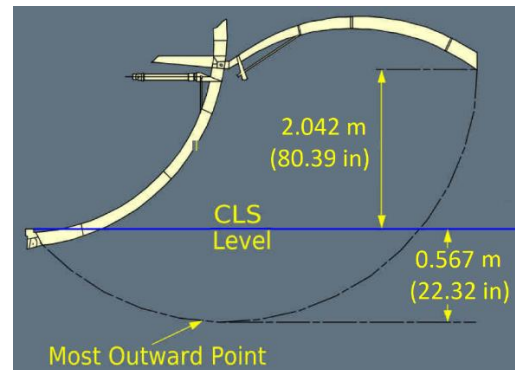
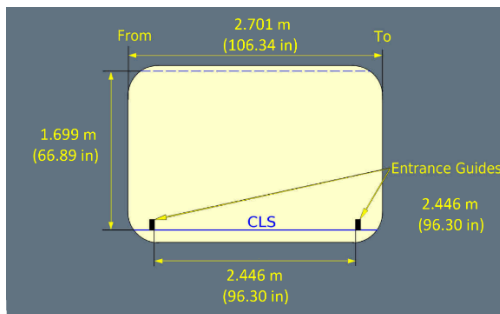

mas

Aerotransportes
 Mas de Carga SA de CV
 Hangar 9 y 10, Zona C,
 Zona Federal
 Aeropuerto Internacional (T2)
 CDMX, Venustiano Carranza,
 C.P. 15620
 masair.com



ULD's Main Deck

SIDE BY SIDE 96"

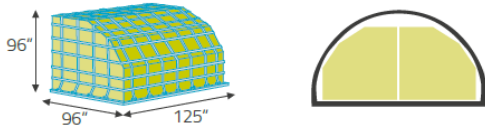

AMA CONTAINERS

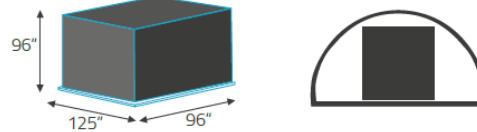

SIDE BY SIDE 88"

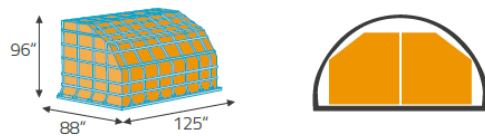

SINGLE ROW 88" & 96"

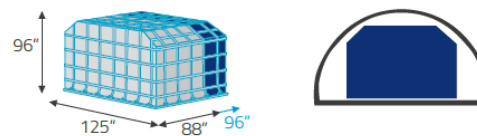

16/20FT PALLET (OPTION)

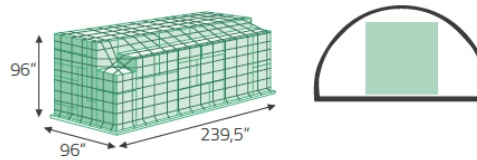
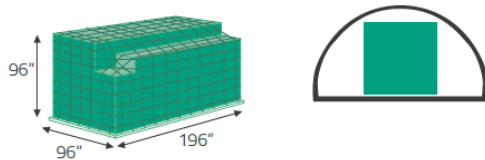

ULD's Lower Deck

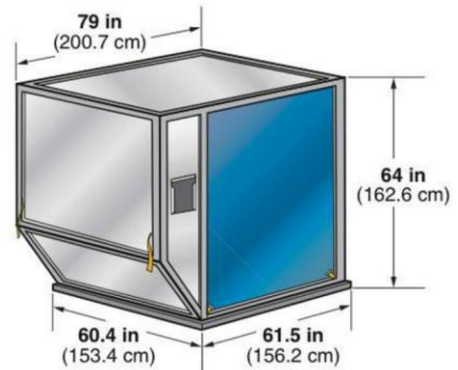
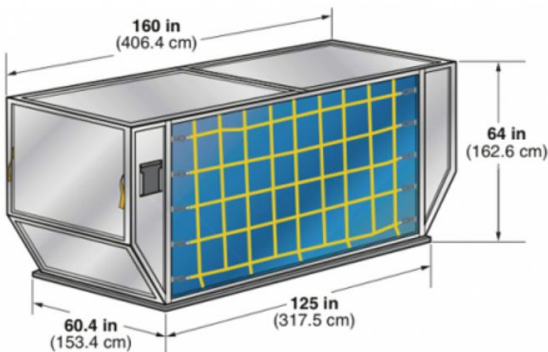

mas

Aerotransportes
 Mas de Carga SA de CV
 Hangar 9 y 10, Zona C,
 Zona Federal
 Aeropuerto Internacional (T2)
 CDMX, Venustiano Carranza,
 C.P. 15620
 masair.com