

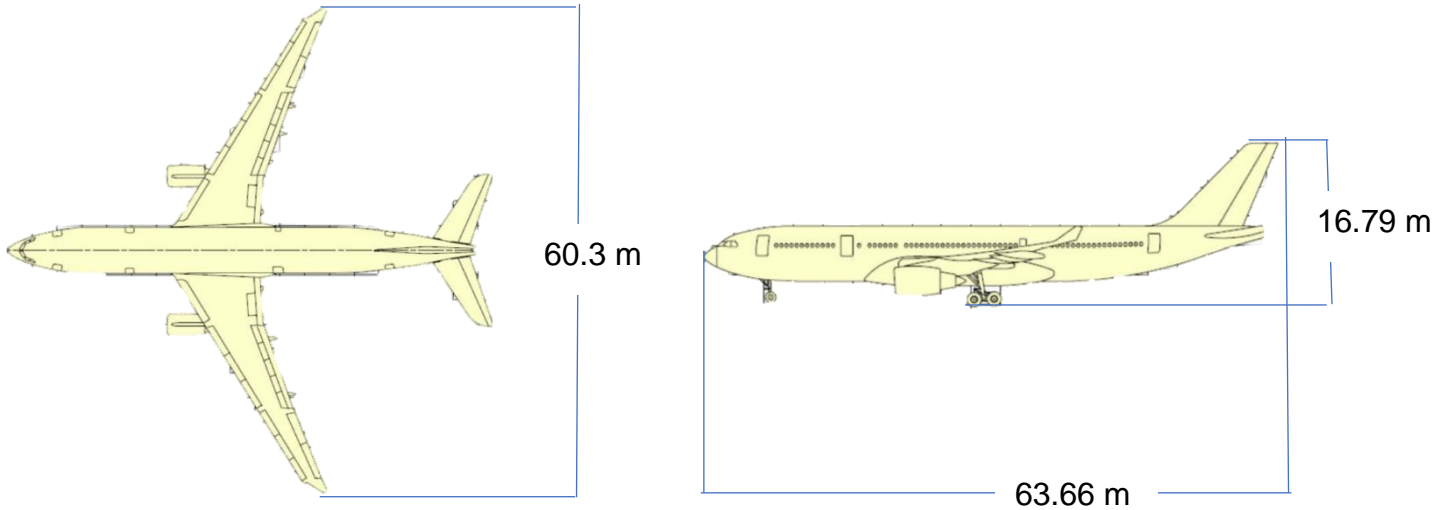

AIRBUS 330-300 P2F

with Rolls-Royce Trent-700



Certified Gross Weights

Description	Pounds	Kilograms
Maximum Payload*	130,072.73	59,000
Maximum Take-Off Weight	533,518.67	233,000
Maximum Landing Weight	412,264.43	187,000
Maximum Ramp Weight	535,502.83	242,900
Maximum Zero Fuel Weight	385,808.95	175,000
Maximum Fuel Capacity	247,878.28	112,435.70

Cargo Compartments Volume

Deck	Capacity
Main Deck	14,796 ft ³
Lower Deck FWD	2,844 ft ³
Lower Deck AFT	2,212 ft ³
Lower Deck Rear Bulk	695 ft ³
Total	20,547 ft³

mas

Aerotransportes
 Mas de Carga SA de CV
 Hangar 9 y 10, Zona C,
 Zona Federal
 Aeropuerto Internacional (T2)
 CDMX, Venustiano Carranza,
 C.P. 15620
 masair.com



A33-300 Cargo Configuration

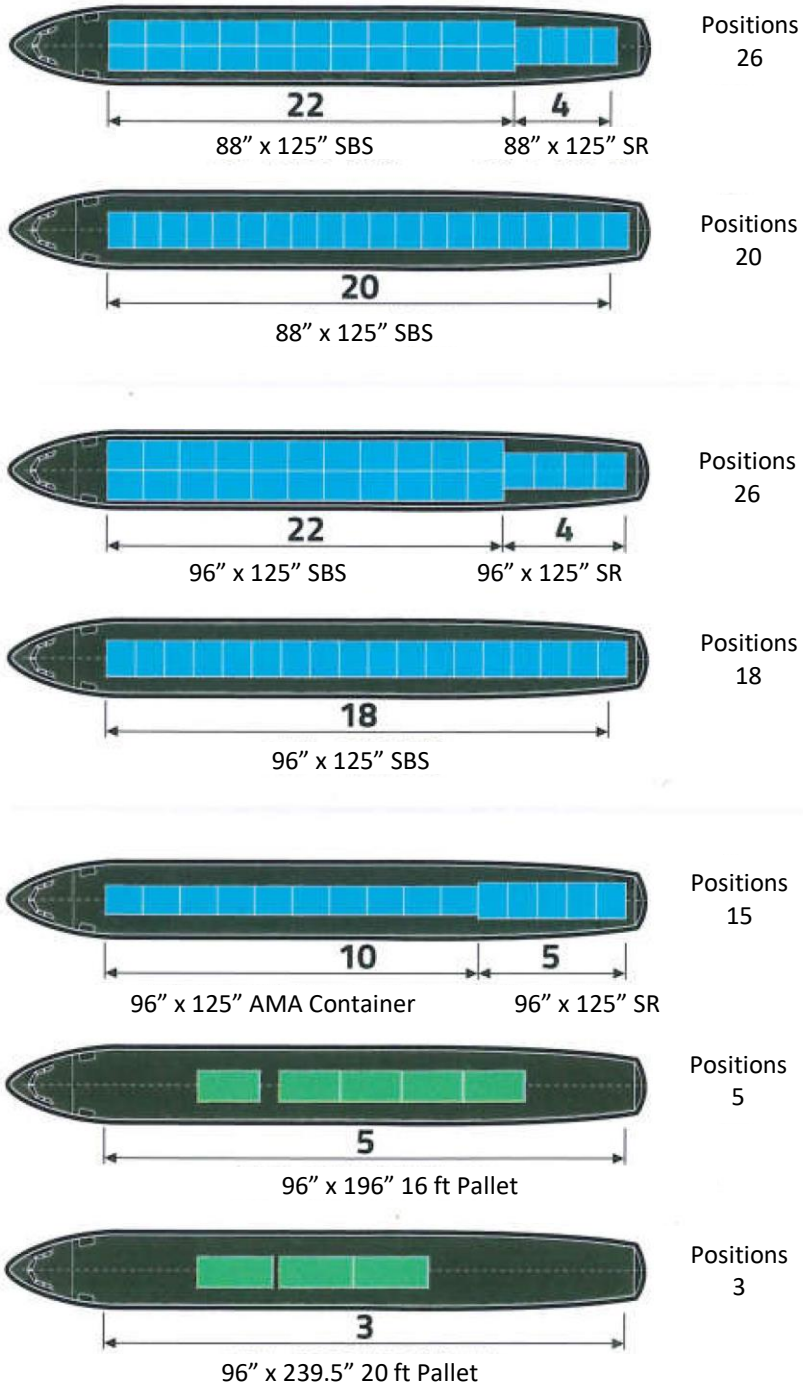

mas

Aerotransportes
Mas de Carga SA de CV
Hangar 9 y 10, Zona C,
Zona Federal
Aeropuerto Internacional (T2)
CDMX, Venustiano Carranza,
C.P. 15620
masair.com



Dimensions Loading Doors – Main Deck

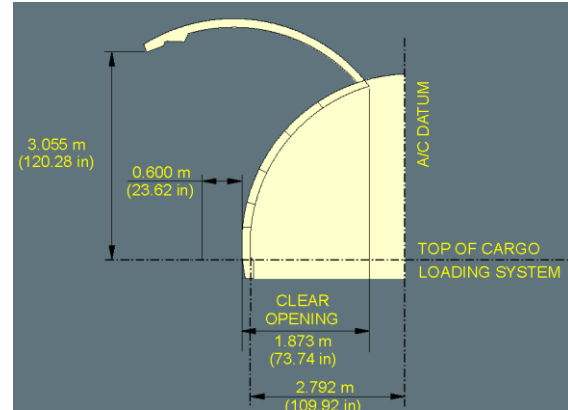
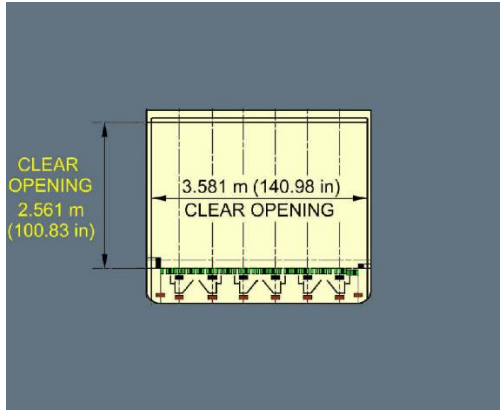

Dimensions Loading Doors – Lower Deck

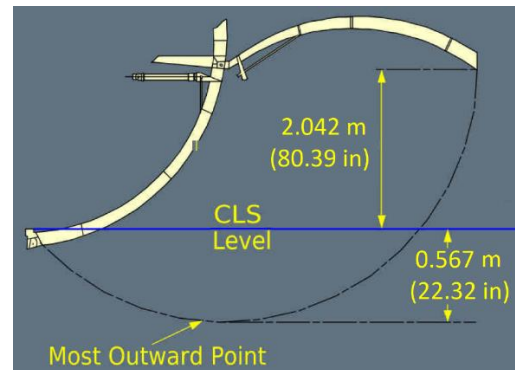
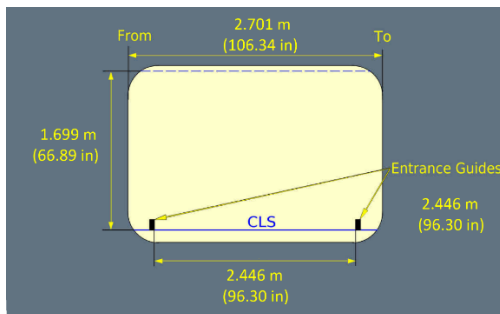

mas

Aerotransportes
 Mas de Carga SA de CV
 Hangar 9 y 10, Zona C,
 Zona Federal
 Aeropuerto Internacional (T2)
 CDMX, Venustiano Carranza,
 C.P. 15620
 masair.com



ULD's Main Deck

SIDE BY SIDE 96"

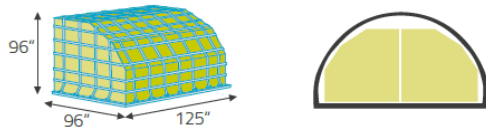

AMA CONTAINERS

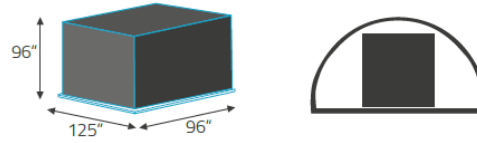

SIDE BY SIDE 88"

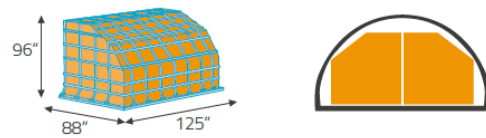

SINGLE ROW 88" & 96"

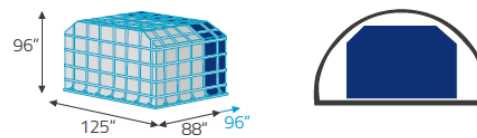

16/20FT PALLET (OPTION)

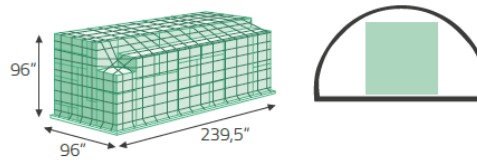
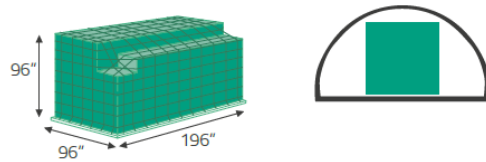

ULD's Lower Deck

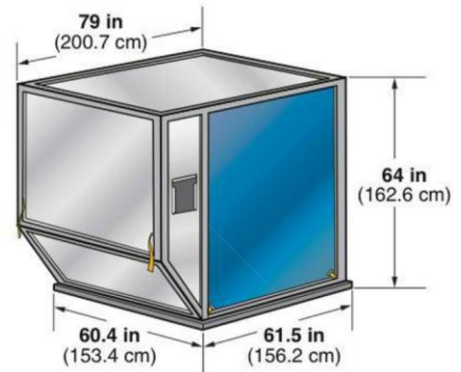
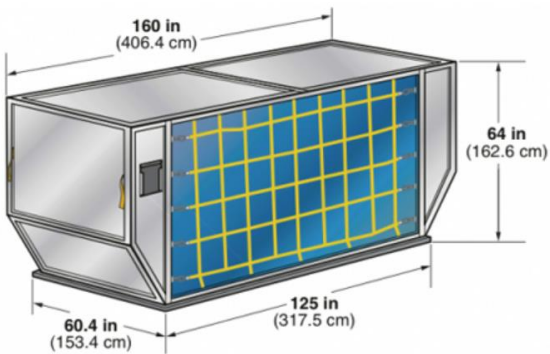

mas

Aerotransportes
 Mas de Carga SA de CV
 Hangar 9 y 10, Zona C,
 Zona Federal
 Aeropuerto Internacional (T2)
 CDMX, Venustiano Carranza,
 C.P. 15620
 masair.com